

# Locking Cage™

Revision Acetabular Hip System



Surgical Technique Guide

# Table of Contents

---

<b>Device Description</b> .....	II
<b>Surgical Overview</b> .....	IV
<b>Surgical Protocol</b>	
A. Acetabular Reaming .....	1
B. Trialing for Locking Cage and Hook .....	2
C. Flange Bending & Assembling Modular Accessories .....	4
D. Locking Cage Insertion .....	5
E. Anchoring .....	6
F. Flange Fixation .....	8
G. Locking Nut Placement .....	9
H. Cementing the Cup .....	13
<b>Order Information</b> .....	15
<b>Instrument Tray Guide</b> .....	17

# Device Description

## Locking Cage –

The Locking Cage is suitable for clinical cases with severe acetabulum deficiency to reconstruct the acetabular structure before the joint prosthesis is mounted on. The Locking cage consists of a locking cage main body and required bone screws for basic fixation. The hook and ischial flange are modular designs for optional use when demand for extra stability exists. The auto break-off locking nut is the key item to complete the locking mechanism, converting the bone screws from their original compressive function to a locking type. The mechanical strength from the Locking Cage structure provides a stable environment for the damaged acetabulum, something required for bony healing.

- Locking Cage main body size from 50 mm to 70 mm.
- Bone screw length from 15 mm to 75 mm.
- Five sizes hook options.
- One size ischial flange

## INDICATIONS

1. Revision of previous unsuccessful acetabular replacement.
2. Class III segmental and/or cavitary acetabular defects which make it difficult to achieve satisfactory results while using standard total hip replacement acetabular components and procedures.

*Please refer to the package inserts for important product information, including, but not limited to contraindications, warnings, precautions, and adverse effects.*



*The United Locking Cage System was designed and developed in conjunction with M.D. Pang-Hsin, Hsieh and Prof. Ching-Lung Tai. This surgical technique is utilized by the surgeon listed above. Each surgeon is responsible for determining the appropriate device and technique to utilize on each individual patient.*

# Surgical Overview

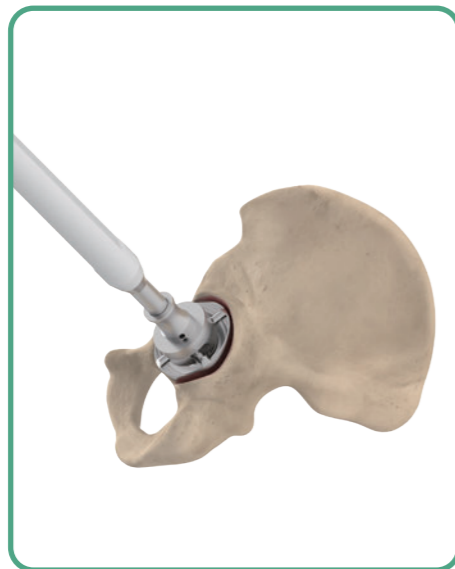

**A. Acetabular Reaming**



**B. Trialing for Locking Cage and Hook**



**C. Flange Bending & Assembling Modular Accessories**

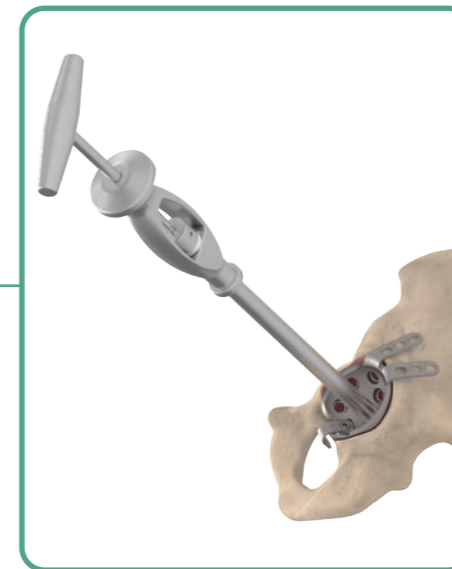

**D. Locking Cage Insertion**

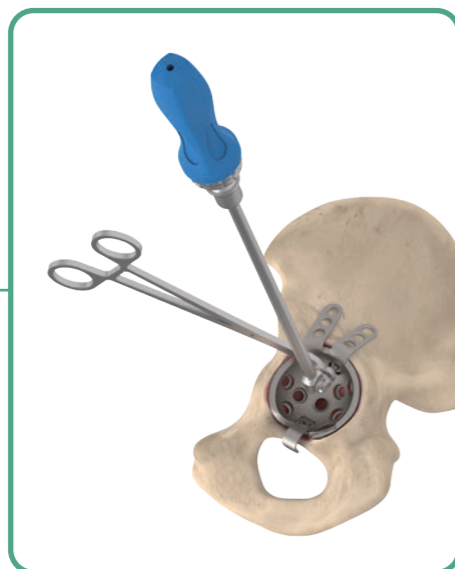

**E. Anchoring**



**F. Flange Fixation**

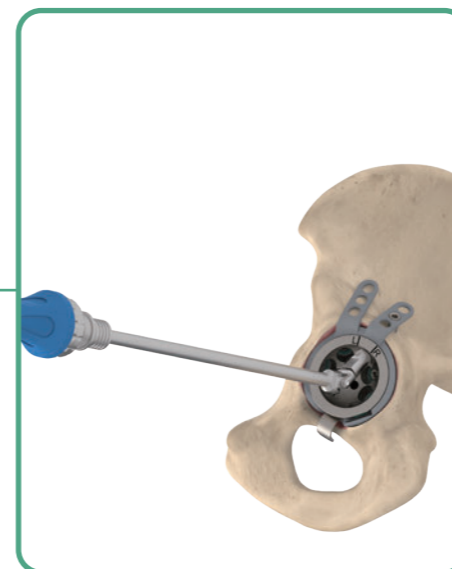

**G. Locking Nut Placement**



**H. Cementing the Cup**

# A. Acetabular Reaming

The acetabulum is sequentially reamed by hemispherical **Cup Reamers** connecting to a **Cup Reamer Handle**. Cavitory defects may need to be filled with morselized bone grafts. Large, segmental defects may be spanned by mesh to contain the graft, while others may require structural bone grafts. The morselized bone graft may be compacted using the last reamer, reaming in reverse.

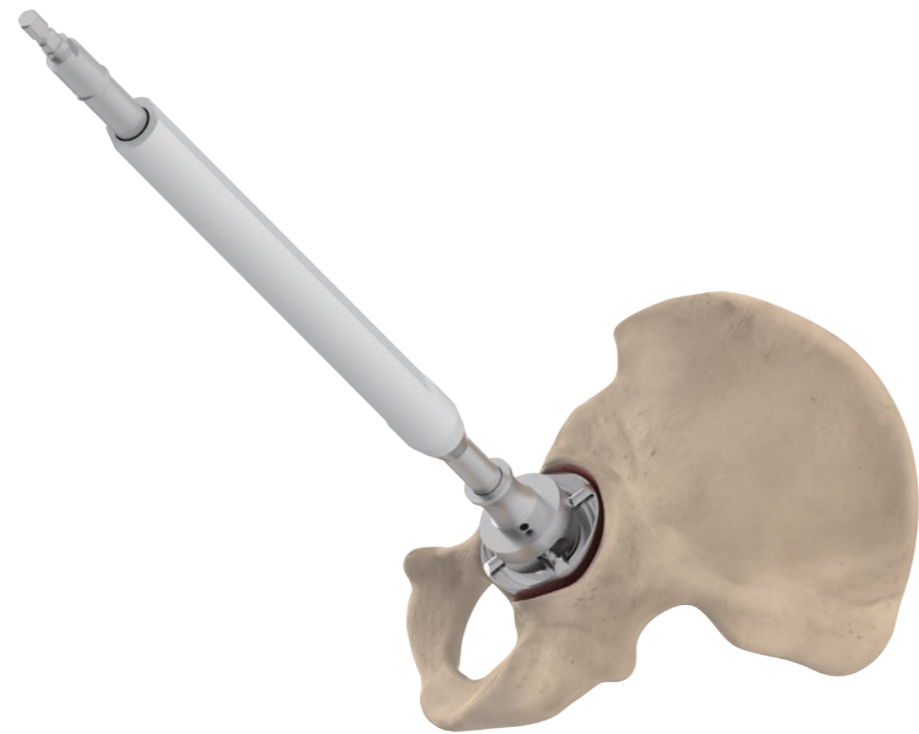

Instruments



Cup Reamer Handle

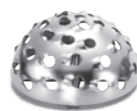

Cup Reamer

# B. Trialing for Locking Cage and Hook

## B1. Trialing for Locking Cage

Assemble the appropriate size **Locking Cage Trial** to the **Cup Impactor**. Using the **Cup Impactor Driver** can further secure the structure for better stability. Insert the selected trial into the reamed acetabular region to confirm the size of the cavity.



Instruments



Locking Cage Trial



Cup Impactor



Cup Impactor Driver

# B. Trialing for Locking Cage and Hook

## B2. Trialing for Hook

If a hook for the cotyloid notch is required, use the **Hook Sizing Template** to determine the required **Hook Trial** size and assemble the selected **Hook Trial** to the **Locking Cage Trial** to confirm the construct together.

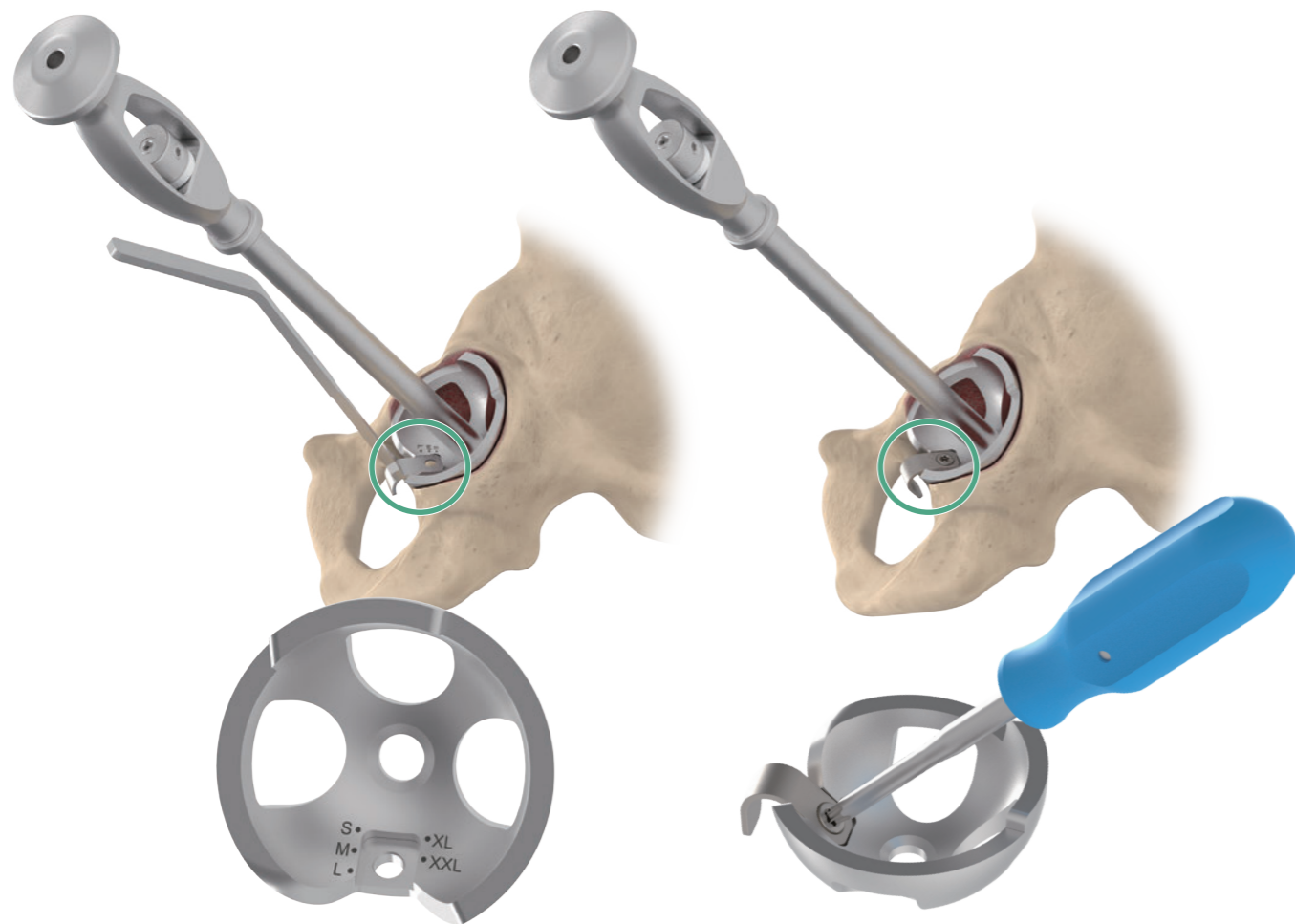

Instruments



Hook Sizing Template

Hook Trial  
S/M/L/XL/XXL

T20 Screwdriver

# C. Flange Bending & Assembling Modular Accessories

To fit the anatomy of the pelvis, bend the iliac flanges on the locking cage using **Flange Bender** to achieve the ideal shape. Assemble the ischial flange and the selected hook to the cage as needed prior to inserting the cage construct into the acetabulum. Bend the hook and ischial flange if needed.

**Caution:**

Avoid reverse or repeated bending of the iliac flanges or the hook. The inappropriate operation may lead to metal weakness and breakage.



Instruments

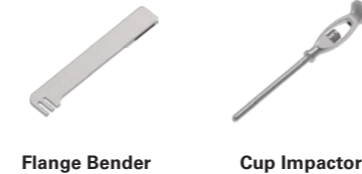

Flange Bender

Cup Impactor

# D. Locking Cage Insertion

Assemble the cage construct to the **Cup Impactor** and fasten using the **Cup Impactor Driver**. Place the cage construct to the appropriate location, adjusting for the required anteversion and inclination. Remove the **Cup Impactor** with the **Cup Impactor Driver**.

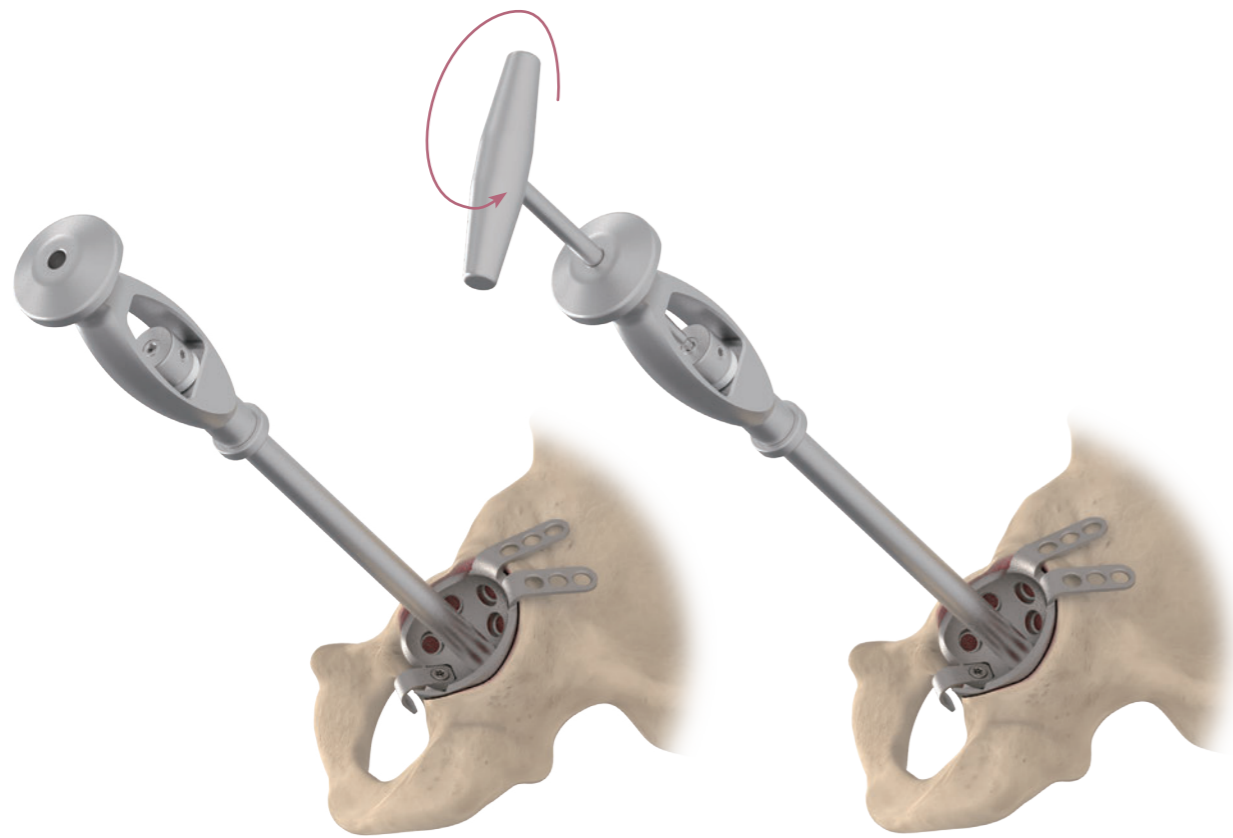

Instruments



Cup Impactor



Cup Impactor Driver

# E. Anchoring

Use the **Flexible Drill** and **Drill Guide** to pre-drill screw holes at the acetabular region in the targeted orientation. Utilize the **Depth Gauge** to determine an appropriate screw length.

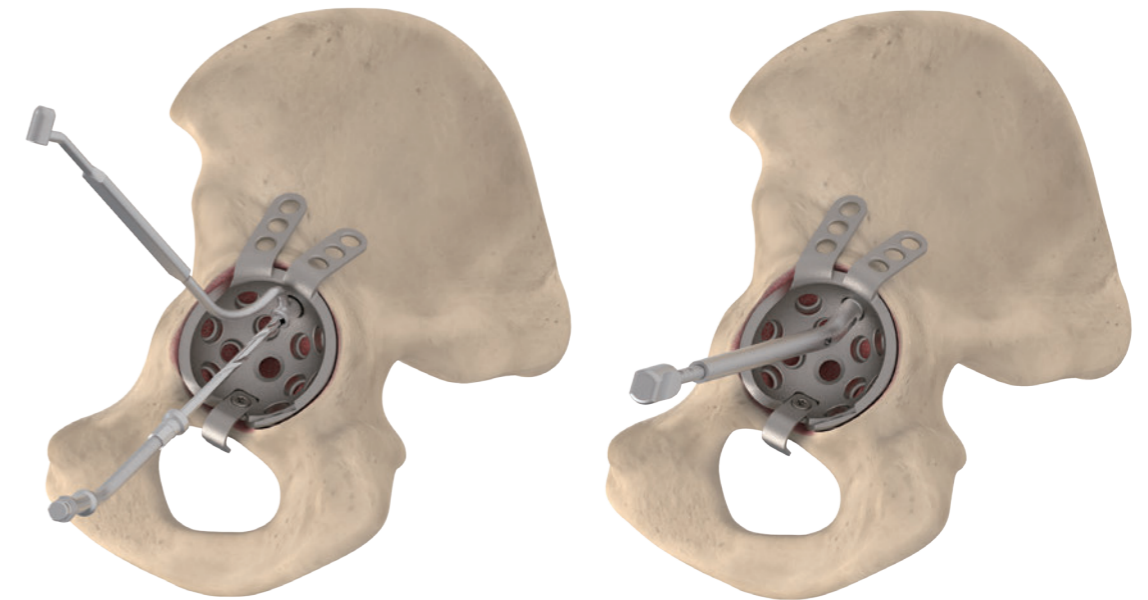

Instruments



Flexible Drill



Drill Guide



Depth Gauge

# E. Anchoring

Use either the **Straight** or **Universal Screwdriver** option assembled with the **Ratcheting Handle** to insert the screw. Use the **Screw Forceps** if needed to hold the screw and help maintain orientation during the securing process. The direction of the screw insertion should follow the pre-drilled screw hole. Secure the screw until the head engages to the cage. Do not over-tighten the screw. Insert enough screws to sufficiently stabilize the cage.

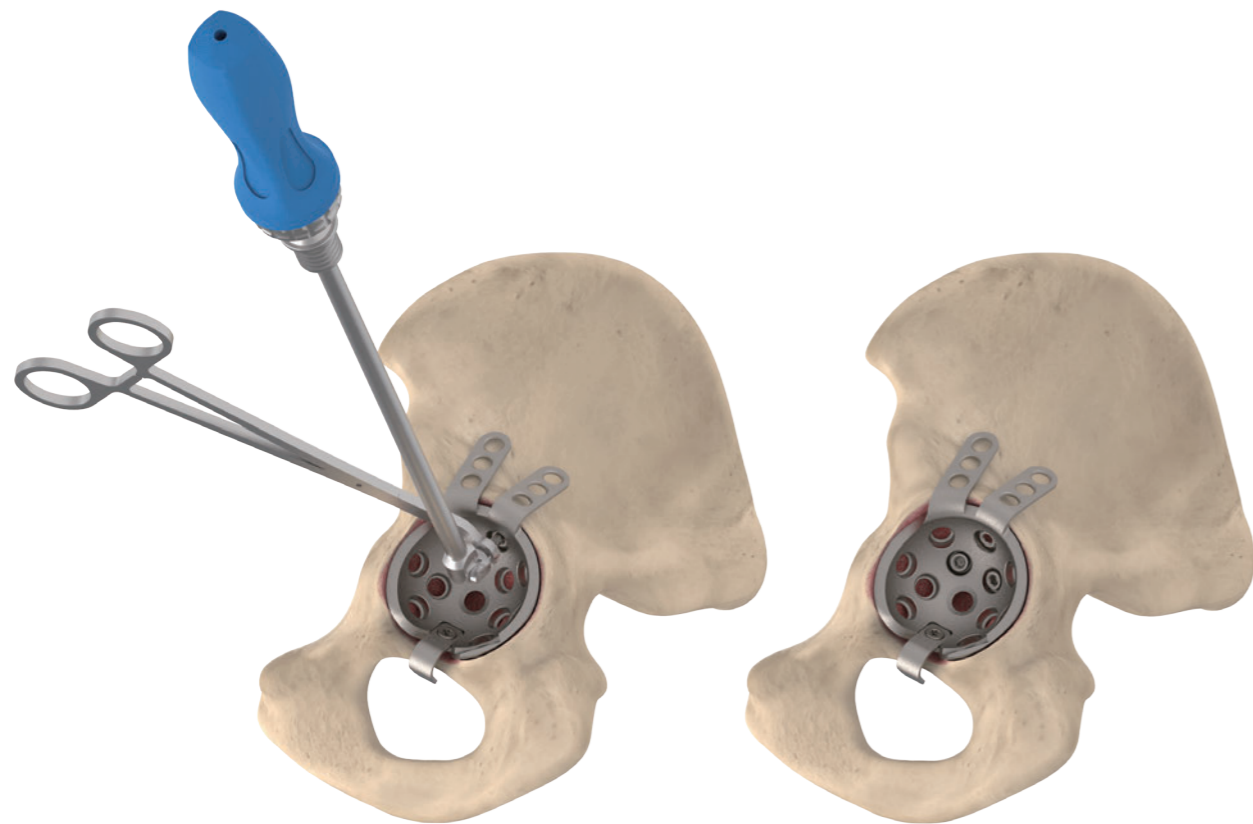

Instruments



T20 Universal Screwdriver

Ratcheting Handle

Screw Forceps

# F. Flange Fixation

Use the **Flange Drill Guide** and **Straight Drill** to prepare the screw holes for flange fixation. Measure the required screw length using the **Depth Gauge**, and insert the screws using the **Screwdriver** attached to the **Ratcheting Handle**. Insert enough screws to enhance the stability of the construct.

An optional ischial flange is available for extra screw fixation.

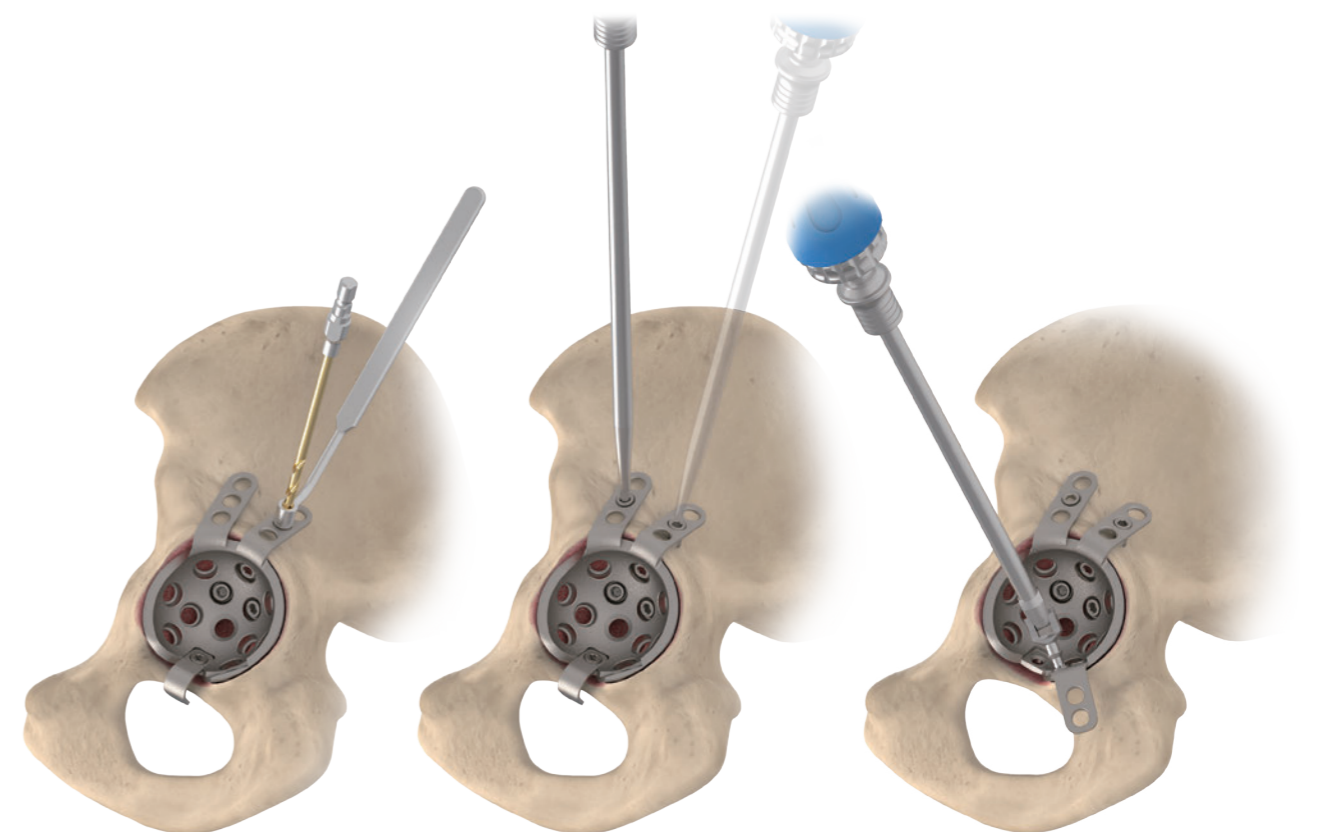

Instruments



Flange Drill Guide

Straight Drill

Straight Screwdriver

T20 Universal Screwdriver

Ratcheting Handle

Screw Forceps

# G.Locking Nut Placement

The poly-axial bone screw is designed to provide flexibility in selecting the optimal direction for screw insertion. In addition, the unique locking nut provides enhanced stability for the fixed structure by converting the compression screws into locking screws.

The locking nut features a break-off mechanism to act as a torque-limiter for optimized locking strength and to avoid a 'cold-welding' effect between screw threads. Break the neck of the locking nut with the **Straight Screwdriver** attached to the **Ratcheting Handle**. This will leave the cap fully secured onto the locking cage.

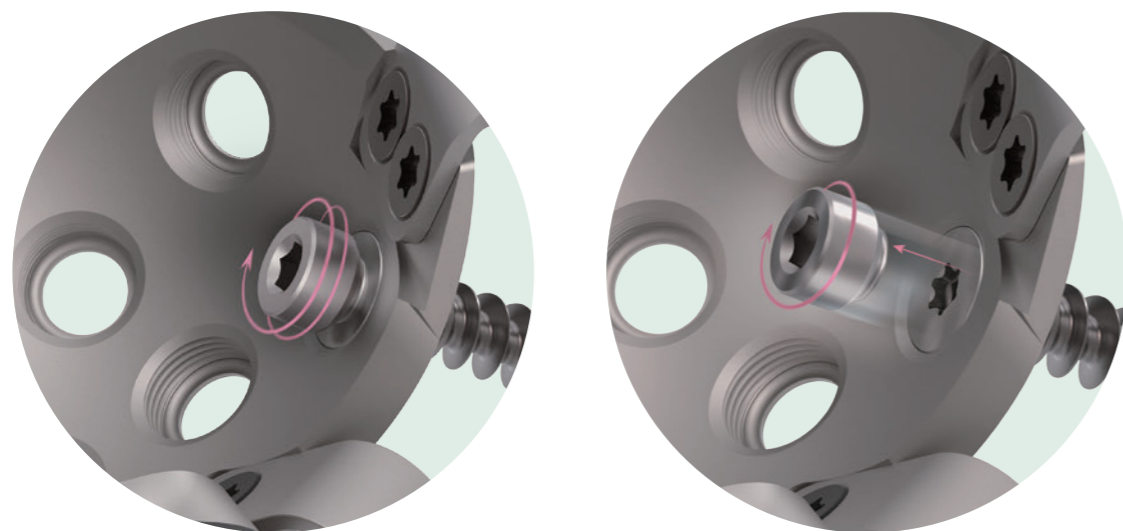

**Locking Nut**

Break the neck of the **Locking Nut**, and leave the cap fully secured onto the Locking Cage.

Instruments



**Straight Screwdriver**



**Ratcheting Handle**

# G.Locking Nut Placement

For sealing the superior screw holes with the locking nuts, the **Nut Guide** is designed to ease the targeting of the locking nuts.

Place the **Nut Guide** into the cage. The mark representing the current operation side should be aligned between the iliac flanges on the cage. Use the **Straight Screwdriver** to secure the **Nut Guide Peg** through the **Nut Guide** tunnel to the cage. Inserting two pegs at inferior region of the cage should be sufficient for stabilizing the **Nut Guide**.

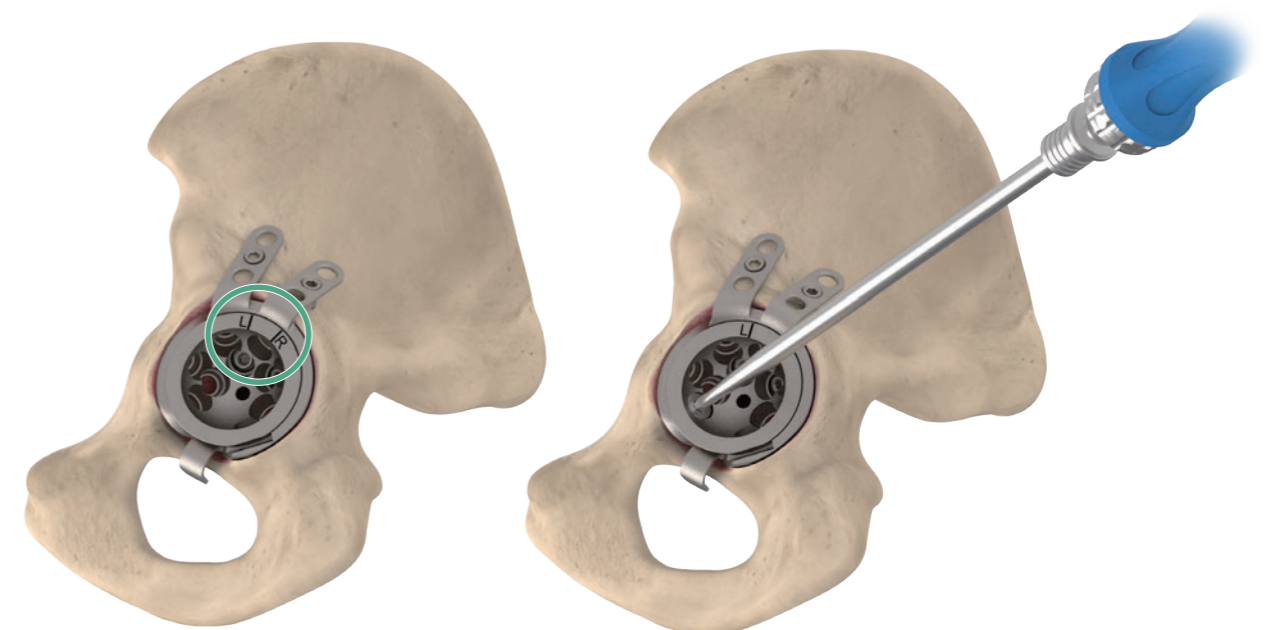

The **Left** or **Right** indicator shall be aligned between the flanges.

Instruments



**Nut Guide**



**Nut Guide Peg**



**Straight Screwdriver**



**Ratcheting Handle**

# G.Locking Nut Placement

Assemble the **Nut Holder** with **Ratcheting Handle**. Hold the handle and turn the barrel region to the default position. Place the auto break-off locking nuts into the barrel of the **Nut Holder**, and engage with the hexagonal driver. Insert the barrel region of the **Nut Holder** into the **Nut Guide** tunnel to lock the corresponding bone screw onto the cage.

Secure the locking nut until the **Nut Holder** stops advancing, then keep providing torque to break the neck of the locking nut, leaving the cap be fully secured onto the cage. Retrieve the **Nut Holder**, hold the barrel region and turn the **Nut Holder** in reverse so the head of the locking nut can be removed. By inserting sufficient locking nuts to convert all inserted bone screws into locked ones.

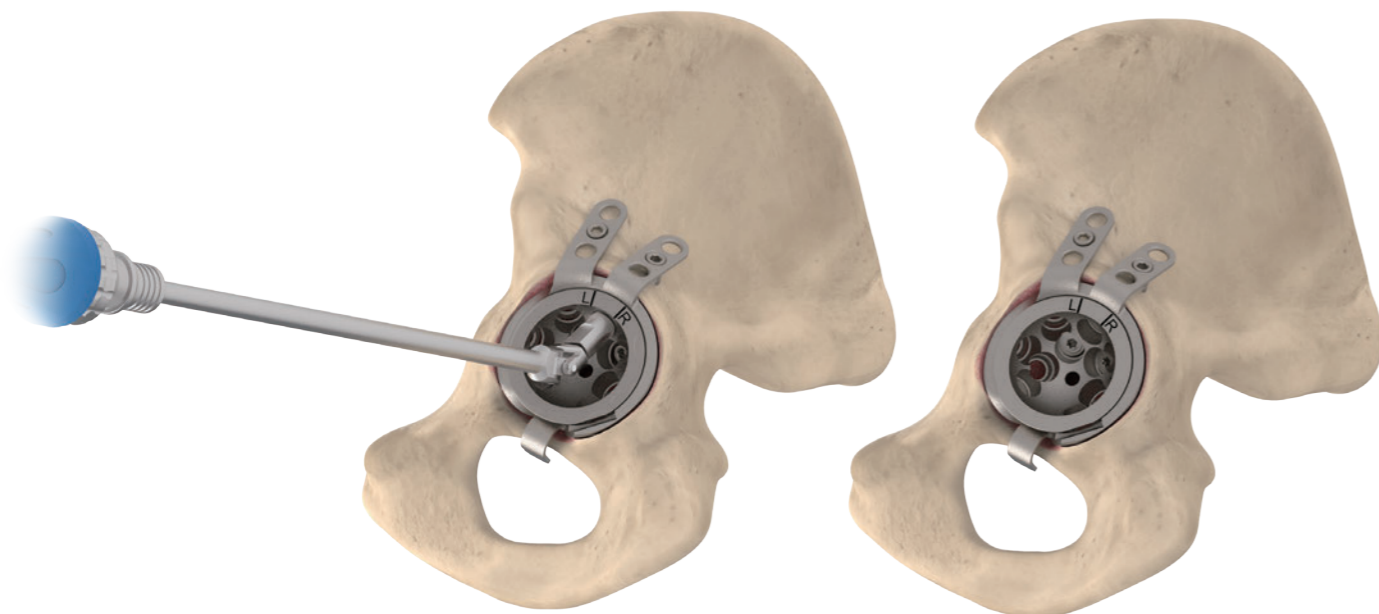

**Note:**

The barrel of the **Nut Holder** should be secured back to its original place (engaged without thread exposure) prior to placing the locking nut into the barrel for insertion.

Instruments



Nut Guide



Nut Guide Peg



Nut Holder



Ratcheting Handle

# G.Locking Nut Placement



Turn the barrel region to the default position.

Place the locking nut into the barrel region.

Turn the barrel region in reverse to retrieve the broken head engaged inside.

The cap can be retrieved by using the **T20 Universal Screwdriver** when needed.

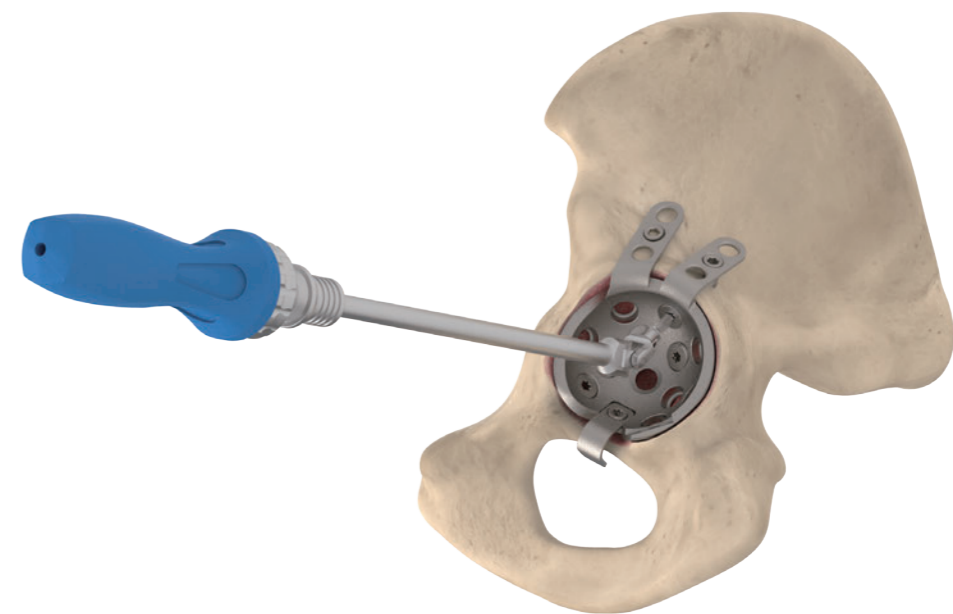

Instruments



T20 Universal Screwdriver



Ratcheting Handle

# H. Cementing the Cup

Test the cup positioning with the cup trial. The thickness of the locking cage is 4mm, while extra cement mantle thickness can be acquired with the use of a smaller cup size.

Put the cement into the locking cage. Position the cup, then remove the redundant cement. Apply pressure to the cup and hold the cup in position until the cement is fully set.

## Locking Cage, Full XPE Cup and UDM Cemented Cup Compatibility Guide

(Recommended maximum size)

Cage Size Cup Size	50 mm	54 mm	58 mm	62 mm	66 mm	70 mm
42 mm	●	●				
44 mm						
46 mm		●	●			
48 mm						
50 mm			●	●		
52 mm						
54 mm				●	●	
56 mm						
58 mm					●	●
60 mm						
62 mm						●







Recommended Full XPE Cup size  
( 2.5 mm cement mantle )



Recommended UDM Cemented Cup size  
( 2 mm cement mantle )

# Order Information

	Catalog Number		Description
<b>Locking Cage</b> Made with Titanium (Ti-6Al-4V) Alloy 	<b>Left</b>	<b>Right</b>	<b>Outer Diameter</b>
	1308 - 1150	1308 - 1250	50 mm
	1308 - 1154	1308 - 1254	54 mm
	1308 - 1158	1308 - 1258	58 mm
	1308 - 1162	1308 - 1262	62 mm
	1308 - 1166	1308 - 1266	66 mm
	1308 - 1170	1308 - 1270	70 mm
<b>Locking Nut</b> Made with Titanium (Ti-6Al-4V) Alloy 	1908 - 5001		
<b>Hook</b> Made with Titanium (Ti-6Al-4V) Alloy 	1908 - 5201		Small
	1908 - 5202		Medium
	1908 - 5203		Large
	1908 - 5204		X- Large
	1908 - 5205		XX- Large
<b>Ischial Flange</b> Made with Titanium (Ti-6Al-4V) Alloy 	1908 - 5401		
<b>Cancellous Locking Screw</b> Made with Titanium (Ti-6Al-4V) Alloy 	5208 - 1015		Ø 6.5 × 15 mm
	5208 - 1020		Ø 6.5 × 20 mm
	5208 - 1025		Ø 6.5 × 25 mm
	5208 - 1030		Ø 6.5 × 30 mm
	5208 - 1035		Ø 6.5 × 35 mm
	5208 - 1040		Ø 6.5 × 40 mm
	5208 - 1045		Ø 6.5 × 45 mm
	5208 - 1050		Ø 6.5 × 50 mm
	5208 - 1055		Ø 6.5 × 55 mm
	5208 - 1060		Ø 6.5 × 60 mm
	5208 - 1065		Ø 6.5 × 65 mm
	5208 - 1070		Ø 6.5 × 70 mm
	5208 - 1075		Ø 6.5 × 75 mm

\*Ti-6Al-4V is an abbreviation for Titanium-6 Aluminum-4 Vanadium.

# Instrument Tray Guide

## Locking Cage Tray 1

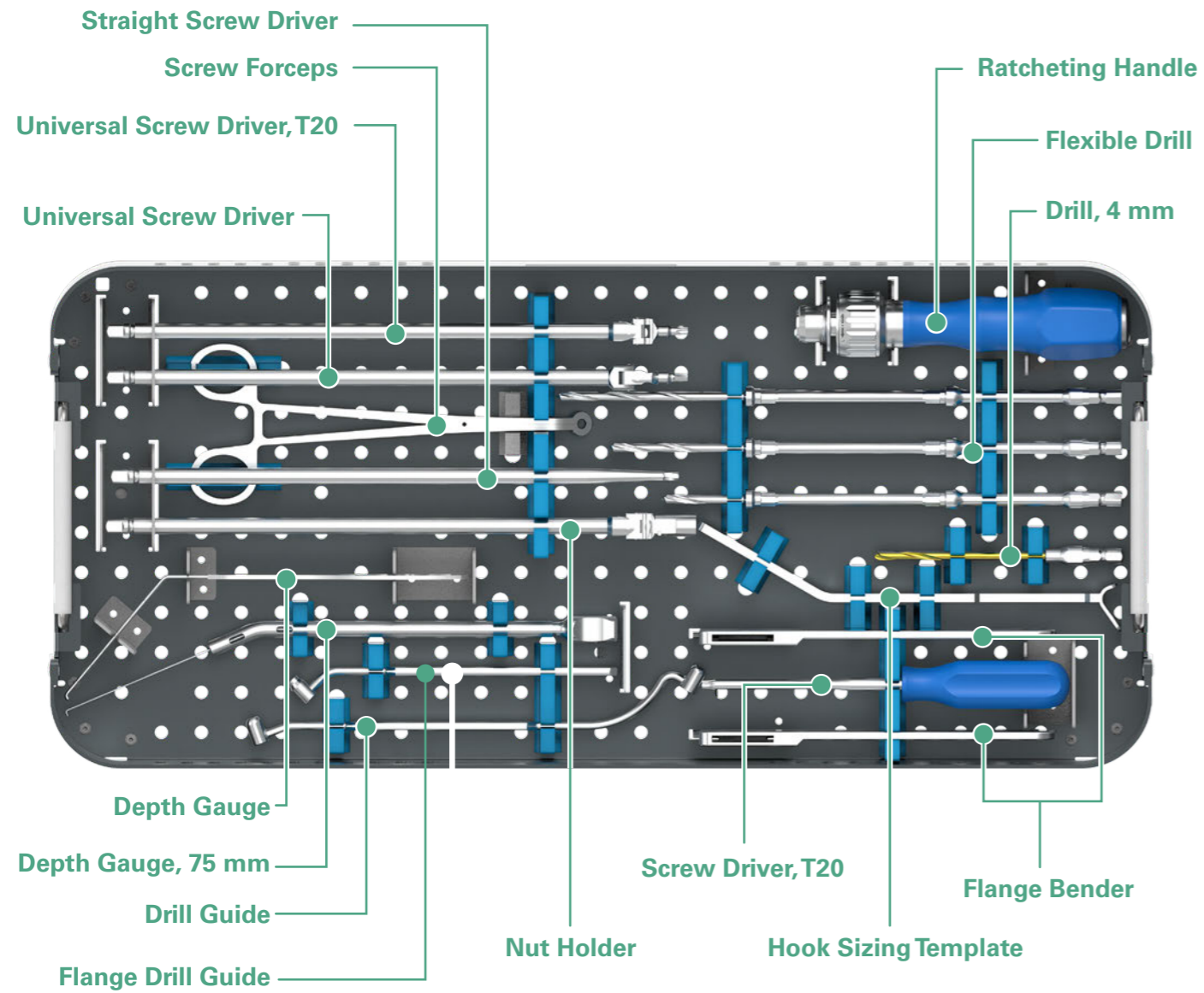

# Instrument Tray Guide

## Locking Cage Tray 2 / Caddy

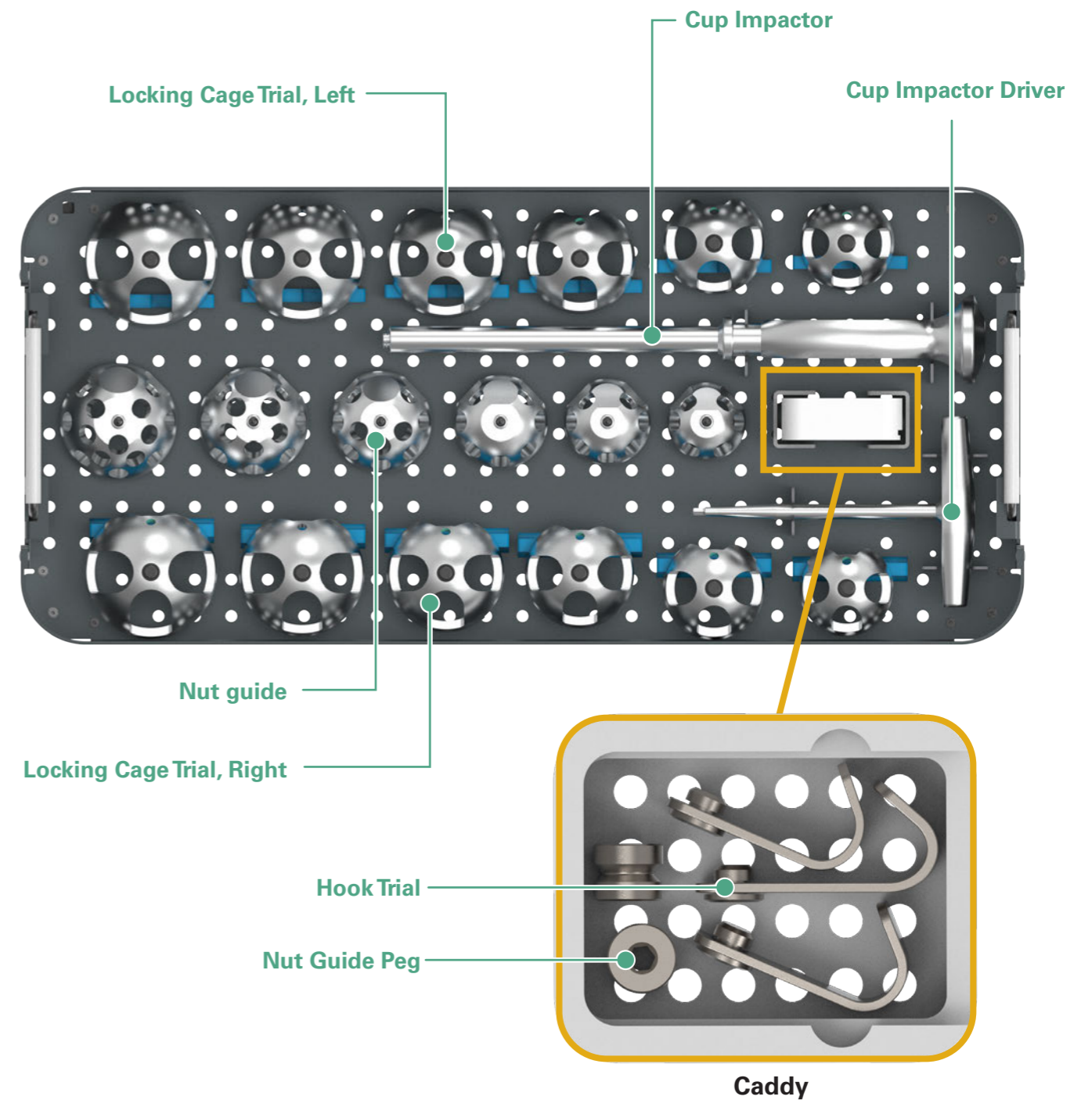



Each Step  
We Care

Please note that this Surgical Technique Guide has been authored in the English language. Any translations into other languages have not been reviewed or approved by United Orthopedic Corporation and their accuracy cannot be confirmed. Any translated guide should be reviewed carefully prior to use and questions regarding a Surgical Technique Guide should be directed to United Orthopedic Corporation at [unitedorthopedic.com/contact](http://unitedorthopedic.com/contact)

